

Universal Solid –Liquid Separator

Universal centrifugal-action separator for removal of grit, sand, metal chips and other solids of 50 micron size and above from liquid, this system is perfect to use as pre-filter to extends the life of fine filtration system likes Bag or Cartridge filters.

These separators require little or no maintenance as they are no moving parts to fail or wear out, or any filter media to replace or clean.

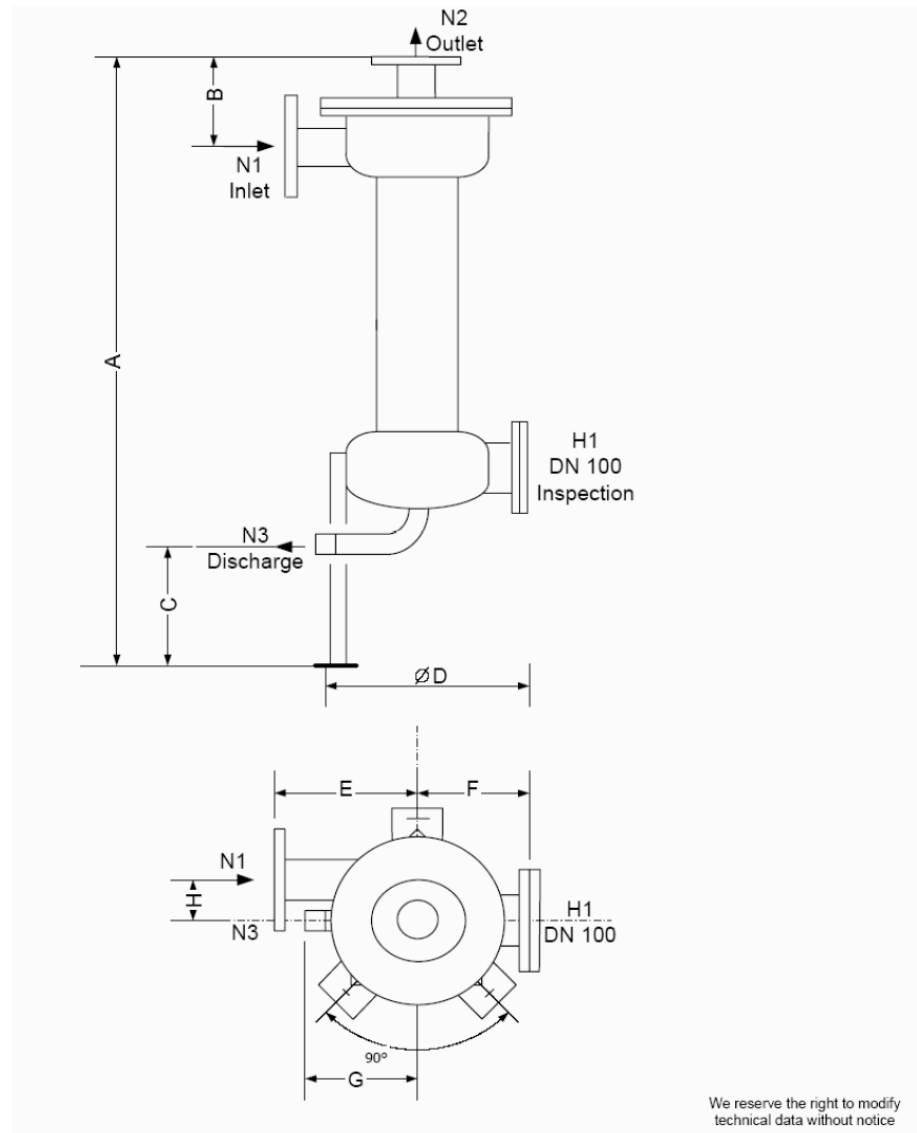

Features –

- Low constant pressure drop
- Stainless Steel SS304 or SS316 material construction
- All housing are mechanical polished to resist adhesion of dirt and scale
- Pipe size from 2” to 4” as a standard
- Other sizes are available on request.

Applications

- Cooling Towers
- Process Water
- Food Processing
- Well Water
- Pulp & Paper Mills
- Steel Mills
- Power Plants
- Chemical Processing
- Spray Nozzle Protection
- Parts Washing
- Pre-filter for Seawater
- Heat Exchanger