

Universal Filtration Bag Filter System Installation & Operation Manual For Automatic Self Cleaning Filter



Contents

- 1 General Information
 - a. Working Principle- filtration & cleaning cycle
 - b. Application
- 2 Control Panel
3. Installation guide
4. Maintenance

1. General Information

a. Working Principle- filtration & Cleaning cycle

USCF filter is a fully automated self cleaning filter system, the whole system consists of filtration media in Stainless Steel mesh structure, fitted with a set of brush that connected to the rotating motor, at the another end of the vessel body installed a solenoid valve controlled discharge valve for draining purpose, during the filtration operation, dirt will be retained at the inner surface of the screen and once the differential pressure build up and exceed the setting differential pressure value (usually set at 0.05 Bar), it send a signal to control panel to switch on the motor as well as the solenoid valve for drain to perform cleaning to remove the dirt, the brush will then rotate and clean up the dirt that retained on the screen inner surface and flow out from drain valve, during the cleaning cycle, filtration is still on without any disruption.

b. Application

USCF is commonly used for the following application where very little maintenance are required.

Cooling Water filtration in cooling tower, air conditioning system, Heat Exchanger to ensure system heat efficiency

Source Water Filtration in river water, lake water, sea water, Well water, under ground water to ensure large particles likes Sands, leave, Stone, Algae removal before treatment.

Industrial use water filtration before pump, polishing machinery, mills, valves, nozzles, heat exchanger to ensure no particles that will cause damage to the expensive equipment.

Pulp & Paper Industry etc.

2. Mode of Operation

Our self cleaning system allows you to perform in

- Automatic Self Cleaning Mode
- Manul Operation Cleaning Mode
- Initial Cleaning on timer setting

Control Panel



4.

Language Selection

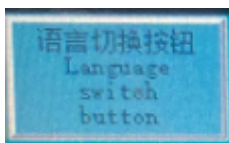

Parameter setting

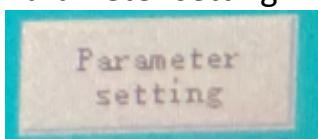

Automatic Operation Mode

During the automatic mode, user can also perform forced backwash but it is important to ensure the motor is turning in clock-wise direction.

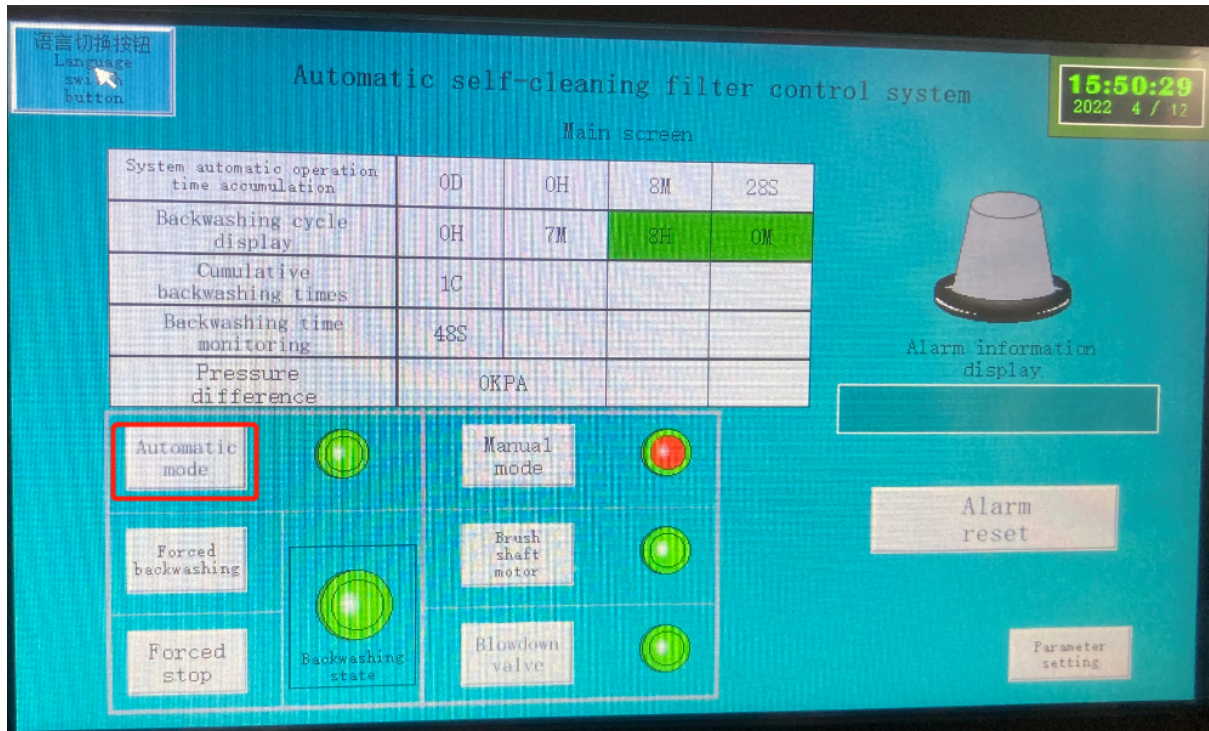

Manual Operation Mode

Select Differential Pressure Intervention

User can select fixed time cleaning mode, default cycle setting at 8 , cleaning timer at 60 sec, user can do setting according to process requirement,m

At default setting, timer only work in automatic mode, backwash frequency is to keep track of cleaning cycle in automatic mode,

Language switch button

Automatic self-cleaning filter control system

15:50:29
2022 4 / 12

Main screen

System automatic operation time accumulation	0D	0H	8M	28S
Backwashing cycle display	0H	7M	32	0M
Cumulative backwashing times	1C			
Backwashing time monitoring	48S			
Pressure difference	OKPa			

Alarm information display

Alarm reset

Parameter setting

Automatic mode

Manual mode

Forced backwashing

Forced stop

Backwashing state

Brush shaft motor

Blowdown valve

Automatic self-cleaning filter control system

15:49:21
2022 4 / 12

System parameter setting

Backwashing cycle setting	8H	0M
Backwashing time setting	60S	
Differential pressure signal timeout	300S	
Differential pressure backwashing timeout	300S	
Differential pressure threshold	80kPa	
Transmitter range	200kPa	

Electric valve selection

Differential pressure intervention

Cumulative time reset (long press for 3 seconds)

Reset the backwashing times (long press for 3 seconds)

Backwashing cycle reset (long press for 3 seconds)

Return to home page

3. Installation guide

a. Before Installation

There are a few important instructions that you have to take note of before doing set up.

- Please make sure you read the manual first before installation
- Please ensure the filter is installed at a safe, non-hazardous location.
- Try to install this filter near to the pressure source, like a short distance to the pump, to avoid too low inlet pressure occurring during the cleaning cycle
- Make sure the filter installation area has enough space to carry out maintenance and operation work
- To ensure inlet pressure to the filter is not less than 0.1 bar during the cleaning cycle
- To ensure the inlet connecting pipe to the filter has the same diameter as the filter inlet connection
- Install valves at inlet, outlet and bypass line prior to the filter
- In situations of water hammering and water backflow along the pipeline, you need to install a check valve after the filter.
- Ensure the water flow consistency between the filter and general piping
- Ensure you have enough head or sideways space to remove the screen for maintenance purposes
- If the filter is used for hot water applications, please ensure you have proper insulation to avoid direct contact with human hands or skin.
- During installation, use proper lifting devices and ensure no other person is nearby for safety reasons
- Wear a Safety Helmet during installation and maintenance.

b. System Set up and running

After checking to ensure all connection wiring is proper, you may switch on the power source, turn on the power switch at the control panel, the screen on the panel should be now on.

Check the motor, switch on the system to manual mode at the control panel and the motor should start to rotate, the brush should rotate in a clockwise direction. If the

motor rotate in anti clock wise direction, you need to check the wiring connecting to motor

Slowly turn on the inlet valve, if possible, not to turn on the outlet valve but to allow the by pass valve to turn on at this moment, manually switch on the discharge valve

Now switch off the by pass valve to let the system to run properly, switch the system now to automatic mode at control panel.

Cleaning cycle should be in less than 60 sec, observe to see if the discharge valve is open properly, after cleaning, the discharge should be now closing.

In case of Power Failure

- Check Power Cable Connection
- Check Power voltage, 24 V.
- If panel screen not working, check the power voltage to ensure is 24V supply
- Check all wiring
- During servicing, please ensure work to be carried out by qualified electrician

System construction

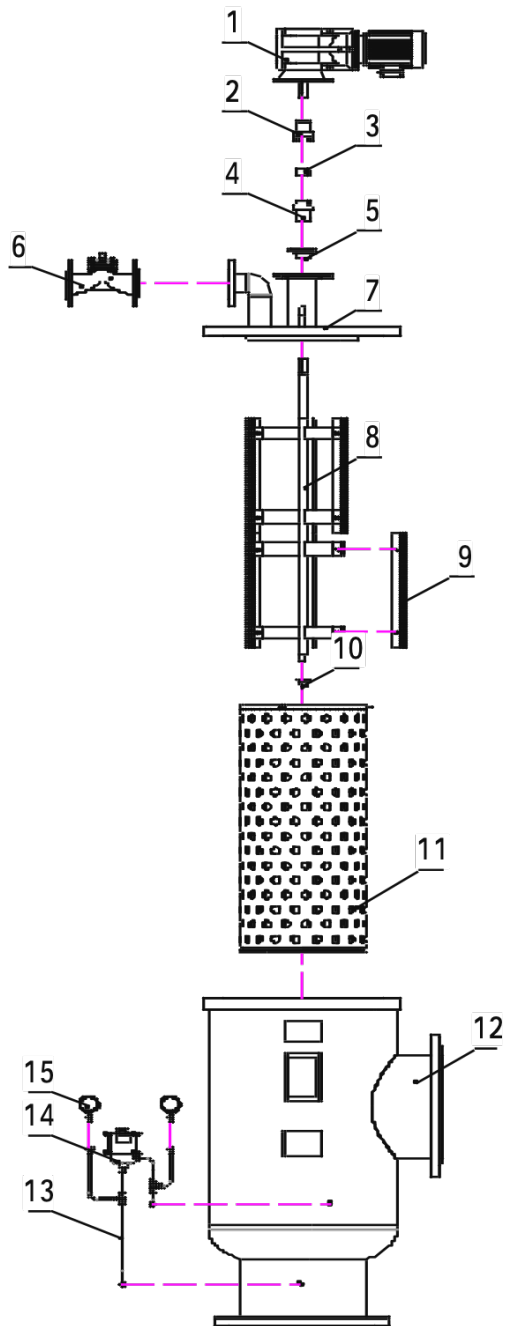

1. Motor
2. Connector
3. Seals
4. Connector
5. Flange
6. Solenoid Drain Valve
7. Top Cover
8. Cleaning Brush Assembly
9. Brush
10. Seal
11. Filtration Screen
12. Body
13. Pressure Indicator
14. Differential Pressure

4. Maintenance

a. Regular Maintenance

Weekly maintenance is required to ensure the system is working properly

- Check if the Solenoid valve functioning properly
- Check if the Motor functioning properly
- Check if the motor shaft that connecting to cleaning brush functioning properly
- Check if the motor & Solenoid valves are properly closed after cleaning cycle.

Maintenance after long period of not using the system

- You should perform the following if you do not intend to use the filter system for more than 1 month period
 - Perform one cleaning cycle, if possible switch off the inlet valve
 - Off the power source of control panel
 - Release all pressure inside the filter, drain out all the water.
- Restart the system after a long break
 - Change the brush and sealing material
 - Connect the power source
 - Check the complete filtration and cleaning cycle to ensure it is functioning properly
- Yearly maintenance, you need at least once per year
 - Check if the system has any leaking issue, open up and check all the sealing, change if not using for long time or damage
 - Check the brush contacting surface with the screen, if is not in proper contact, you need to remove the screw and do some adjustment.
 - Change the brush if found damaged
 - Change the screen if found damaged